

The Seminole Flyer

www.seminolerc.com



A chartered member of the
Academy of Model
Aeronautics
AMA Charter #216, 1969-2008



"The Seminole Flyer" is a publication of the Seminole Radio Control Club of Tallahassee, Florida

OCTOBER 2008

INDEX

- Letter from the Editor
- Club Calendar
- Chief Pilot Report
- Chief Copilot Report
- Chief Treasurer Report
- Chief Scribe Report
- How to Align Cabane Struts
- How are your Nicads?



Letter from the Editor- Stephen Warmath

I hate love bugs! They seem to be everywhere. Maybe with our recent sniff of fall weather, they are on the way out. I do enjoy the fall. Flying weather is more tolerable and the long look down the holiday road brings a smile to my face. Because Daylight savings is reverting three weeks later than normal this year, it was decided, at our last meeting to have **October's meeting at the field- 7:00 pm.**



Aligning those pesky **cabane struts** can be frustrating. This month's article offers one simple solution. **How are your Nicads?** Reminder of checking your batteries and replacing them before a problem arises.

BEWARE

of ghosts
goblins
ghouls
& things
that go
bump
in the
night



It's also time to start thinking about December Elections. Club Officer nominations or (volunteers) are due at our November meeting. Please send me your nominations or willingness to run by October 23rd. Remember, if you nominate someone; make sure they are willing to accept the nomination first. To refresh everyone's memory the following excerpt from our Constitution, outlines the responsibilities of the various positions:

ARTICLE VI Duties of Officers

1. **President:** Shall preside at all meetings of the membership, coordinate all committee activities, and enforce the constitution and by-laws to the best of his or her ability.
2. **Vice-President:** Shall assist the President in various duties, shall perform the duties of President in his or her absence, and shall be chairman of the Activities Committee.
3. **Secretary:** Shall take minutes, keep records, accept applications, correspond, and perform any other duties deemed necessary by the membership in order to keep the club's business in an orderly manner. *(Note: Historically, the Secretary has accepted the duty of Newsletter Editor. This is not a requirement and is strictly voluntary. These two responsibilities may be held by separate members. The Secretary is an elected officer and the Newsletter Editor is a voluntary position.)*
4. **Treasurer:** Shall maintain all of the club's cash and material assets, write and sign checks at the discretion of the President or Vice-President, and perform any other duties deemed necessary by the membership.

Note: Newly elected Officers assume their duties at the conclusion of the regular December meeting, not January 1.

Having said all that, I have decided to step down as Secretary and Newsletter Editor in December. After three years, it's time to share the fun. I will provide the new Newsletter Editor the tools and information to carry on with the current format if desired. The new editor, conversely, can create his or her own format. I appreciate the kind words from the members in the past regarding the newsletter. It's been fun.

Happy Building and Flying- Steve :o)

Chief Pilot- Shannon Black

Well, fall seems to have finally arrived. The days are getting shorter, football is in full swing, and more of us seem to be enjoying the cooler weather with a trip to the airfield. It's hard to believe that it is October already. Soon, the holidays will be upon us, and we'll be dealing with club elections. Sam Varn has already informed us that he will not be able to continue as our treasurer. With this in mind, please think of offering your services as a club officer. I have learned a lot about our club this past year by being president, and I would like to think that we all have something that we can offer as an officer. If you are one of the members that would like to see some changes made, please step up and help make our club a better one.

Don't forget that we have our fall Fly-In scheduled for October 11th. Lets shoot for a huge turnout and really make this event a success. We also have a float fly scheduled for November and our annual Warbird Fly-In in December.

Until next month, I'll see ya at the field.
Shannon

Club Calendar

October

- 2- Club Meeting at the Field 7:00 pm.
- 4- Fun Fly Series #5
- 11 Fall Fly-In

November

- 6- Club Meeting at Grace Lutheran Church. 7:30 pm.
- 8- Fun Fly Series #6
- 22- Float Fly

December

- 4- Club Meeting at Grace Lutheran Church. 7:30 pm.
- 6- Warbird Fly-In



Chief Copilot- Mike Atkinson

Local Events Update:

Hobytown USA and Seminole RC Club will host our annual Fall Fly-in on October 11, 2008. Currently, the start time will be 12:00, but we will be looking into getting permission to begin flying earlier in the morning. Many thanks to Frank Bastos and Hobytown for their involvement. On a side note.....Most of us remember life before Frank came to town. Perhaps we should enlighten those who don't!

We will have our next Float Fly-in at Lake Surovec on November 22, 2008. We will begin flying at 10:00 and continue until 4:00. More details to follow...

Seminole RC Club will host a Warbird Fly-in December 6, 2008. Since the days will be short at that time of the year, we will also ask permission to begin flying earlier in the day for that event. I would anticipate starting around 9:00 and continuing until 5:00.

See you at the meeting,

Michael Atkinson

Upcoming AMA Regional Events

Salute to Our Military

FL
10/04/08-10/05/08 - Palmetto, FL (C) Salute to Our Military. Site: Club Field. Laura Long CD, 3312 50th Ave E Bradenton FL 34203 PH:941-727-5670 email: lmilong37@aol.com. 500' x 75' grass runway, RV parking, limited hookups, restrooms, food and beverages on site, no turbines, aircraft must be military. Visit www.manateerc.com. Sponsor: MANATEE COUNTY RADIO CONTROLLERS

Rally of Eagles

FL
10/04/08-10/05/08 - Navarre, FL (C) Rally of Eagles. Site: OLS Field Holley. James Weems CD, 106 Willow Ridge Lane Indian Springs AL 35124 PH:205-733-2021 email: jimweems@bellsouth.net. Scale type aircraft only, no ARF allowed, tubines allowed, no camping. Sponsor: HOLLEY FLYERS

2008 Scale Masters Championship

FL
10/09/08-10/12/08 - Sarasota, FL (B Restricted to US Scale Masters Assoc) 2008 Scale Masters Championship

for 512, 522(JSO). Site: Club Field. Jonathan Hay CD, PH:941-377-8676 email: rcflyer@verizon.net. Visit www.sarasotarc.com or www.scalemasters.org. Events will be Expert, Team and Advanced per USSMA. Food on site. Self contained campers ok. No hookups. Sponsor: SARASOTA RC SQUADRON, INC

Giant Scale Warbird Fly In

FL
10/10/08-10/11/08 - Jacksonville, FL (C) Giant Scale Warbird Fly In. Site: Club Field. Monty McMillian CD, 1612 Inkberry Lane Jacksonville FL 32256 email: montague56@hotmail.com. Visit www.gatewayrc.org. Landing fee \$15 both days. Vendors welcome, war birds WWI to present. 60 - 80 rule. Hot food, restrooms, RV parking, no hookups, lets have a great time. Sponsor: GATEWAY RC CLUB

Triple Creek IMAC 2008

FL
10/11/08-10/12/08 - Riverview, FL (AA) Triple Creek IMAC 2008 for 411, 412, 413, 414, 415(O). Site: Club Field. Montgomery Huff CD, 3444 Chadwick Ave Spring Hill FL 34609 PH:352-686-4136 email: planewrappers@tampabay.rr.com. Visit www.triplecreekrc.com. Sponsor: TRIPLE CREEK RC

Gathering of the Turkeys

FL
10/11/08-10/13/08 - Pensacola, FL (AAA) Gathering of the Turkeys for Cat III 101-105C, 120, 122, 124, 128, 140-142(JSO). Site: Navy Heli Sie 8A. George White CD, 5928 Hermitage Drive Pensacola FL 32504 PH:850-473-0866 email: white76@cox.net. Visit www.pensacolafreeflight.com. SAM OT Pylon, Cabin, OT Rubber, FAC OTR, Commercial Rubber, Dime Scale, Jet CLG NFFS Nos Gas, Classic Towline Glider. Sponsor: PENSACOLA FREE FLIGHT TEAM

Fourth Annual Osceola Flyers Fly In

FL
10/11/08-10/12/08 - Kissimmee, FL (C) Fourth Annual Osceola Flyers Fly In. Site: Club Field. Howard Hosenbold CD, 3134 Crested Circle Orlando FL 32837 PH:407-856-2544 email: howardh1951@hotmail.com. Parking fee \$3, no landing fee, vendor, prizes, food and refreshment available. Grass groomed runway 350' x 50'. All pilots and public invited. Visit www.osceolaflyers.com. Sponsor: OSCEOLA FLYERS

Big Bird Fly In

FL
10/11/08-10/12/08 - Morriston, FL (C) Big Bird Fly In. Site: Club Field. Richard Hinton CD, 851 SE 148th Terrace Williston FL 32696 PH:352-528-9729 email: rhinton1@erbarqmail.com. Sponsor: THE OWLS

Jets Over the Cape

FL
10/11/08-10/12/08 - Cape Coral, FL (C) Jets Over the Cape. Site: Club Field. Edward Gamils CD, PH:941-575-8047 email: egamils@hotmail.com. Sponsor: CAPE CORAL R/SEA HAWKS

Emerald Coast Model Aviators 18th Annual Fly In

FL
10/11/08-10/12/08 - Wewahitchka, FL (C-Restricted to IMAA) Emerald Coast Model Aviators 18th Annual Fly In. Site: Parker Farms Campground. Doug Sampson CD, 7476 Shadow Bay Dr Panama City FL 32404 PH:850-874-2932 email: dgsampson@comcast.net. \$10 landing fee, limited full hookups, RV parking call 850-639-5204 for reservations, Sat dinner free to pilots and families, noon combat demo and candy drop, 100' x 700' grass runway, excellent concession stand, site is 2 miles W of Wewahitchka just off Hwy 22, follow air show signs. Sponsor: EMERALD COAST MODEL AVIATORS

Fighter Town Military Fly In

FL
10/18/08 - Land O' Lakes, FL (C) Fighter Town Military Fly In. Site: Club Field. Gene Monroe CD, 4218 Harbor Lake Dr Lutz FL 33558 PH:813-948-4350 e-mail: dekester@verizon.net. one day event, any military aircraft, any scale, including electrics. Two 700' grass runways, landing fee \$20, \$15 for WMAA members. Pilots choice awards & event cap. Covered pits, pavilion & full kitchen, current AMA required, vendors welcomed. Sponsor: BAY CITY FLYERS

19th Fall Fling Fly In

FL
10/18/08 - Mossy Head, FL (C) 19th Fall Fling Fly In. Site: 3171 Richardson Road. James Giffard CD, 4568 Top Flight Drive Crestview FL 32539 PH:850-398-6076 email: jgiffard@cox.net. High noon combat, awards for best trainer, sport, scale, and pilots choice, Swap area, food and drinks on site. Sponsor: CRESTVIEW MODEL AVIATORS

Pioneers of Radio Control

FL
10/18/08-10/19/08 - Cocoa, FL (C) Pioneers of Radio Control. Site: Cocoa Landfill. David Platt CD, 1306 Havre NW Palm Bay FL 32907 PH:321-724-2144 email: misterscale@cfl.rr.com. Vintage Radion Control Society eligibility rules. Sponsor: INDIAN RIVER KONTROL SOCIETY

Fall Helicopter Gathering

FL
10/18/08-10/19/08 - Jacksonville, FL (C) Fall Helicopter Gathering. Site: Club Field. Andrew Griffith CD, 1600 Chain Fern Way Orange Park FL 32003 PH:904-993-4956 email: barracudahockey@aol.com. Visit www.jaxrc.com. Rotary wing only. Scale or 3D, nitro or elec, Autogyros ok. Modern facility with covered pits, paved runways, pilots prize, concessions and full restrooms, Camping ok, RV's ok, no hookups, night flying, beginners are encouraged. Henry Caldwell, Bobby Smith, Peter Wales and others. \$20 landing fee includes Sat lunch. Sponsor: RC CLUB OF JACKSONVILLE

IMAA District V Mini Festival

FL
10/23/08-10/25/08 - Jacksonville, FL (C-Restricted to IMAA) IMAA District V Mini Festival. Site: Club Field. Ewell Howard CD, PO Box 892 Callahan FL 32011 PH:904-879-2834 email: bhoward32011@aol.com. Landing fee \$20 all the days, Sat 10, landing fee includes BBQ dinner Fir night. Hot food, RV parking, Vendors welcome, Prizes for pilots to be given away Sat afternoon. Sponsor: GATEWAY RC CLUB

Zephyr Electric Fly In Festival

FL
10/24/08-10/26/08 - San Antonio, FL (C) Zephyr Electric Fly In Festival. Site: Club Field. Richard Scott CD, 39521 Keith's Circle Zephyrhills FL 33542 PH:813-779-4091 e-mail: richard.g.scott@att.net . 4th annual ZEPHYR, all electrics welcome, open flying each day, huge raffle, good food. Sponsor: CAN-AM FLYERS

Navy Blue Angels Airshow

FL
10/24/08-10/26/08 - Jacksonville, FL (D) Navy Blue Angels Airshow. Site: NAS Jax. Kevin Wilson CD, 10527 Old Plank Road Jax FL 32220 PH:904-226-1056 email: kevnsher@bellsouth.net. Sponsor: GATEWAY RC CLUB

Ocala Scale Aerobatics

FL
10/25/08-10/26/08 - Ocala, FL (AA) Ocala Scale Aerobatics for 411, 412, 413, 414, 415(JSO). Site: Club Field. Fred Johnson CD, 8504 SE 72nd Ave Ocala FI 34472 PH:352-895-7436 email: rareeagle2@aol.com. Freestyle Sunday, food and camping on site no hookups. Visit www.ocalaflyingmodelclub.com. Sponzor: OCALA FLYING MODEL CLUB

Zephyr Electric Fly In Festival

FL
10/24/08-10/26/08 - San Antonio, FL (C) Zephyr Electric Fly In Festival. Site: Club Field. Richard Scott CD, 39521 Keith's Circle Zephyrhills FL 33542 PH:813-779-4091 e-mail: richard.g.scott@att.net . 4th annual ZEPHYR, all electrics welcome, open flying each day, huge raffle, good food. Sponsor: CAN-AM FLYERS

Warbirds Over DeLand

FL
10/25/08 - DeLand, FL (C) Warbirds Over DeLand. Site: Airport. William Meyer CD, 745 Bay Drive New Smyrna Beach FL 32168 PH:386-426-7853 email: momonsb@ucnsb.net. Visit www.delandrcclub.com. Enjoy Warbird action. For all military aircraft with piston or electric power, Giant Scale 80" mono, 60" biplane rule will apply. No helicopter or turbines allowed. 1000' runway food and refreshments enter field from Marsh Road ½ mile East of Airport on Hwy 92 follow signs. Sponsor: DELAND RC CLUB

Shadetree 21st 4F Fly In

FL
10/30/08-11/01/08 - Glen St Mary, FL (C) Shadetree 21st 4F Fly In. Site: Club Field. John Mason CD, PO Box 1436 Glen St Mary FL 32040 PH:904-868-2813. Visit www.shadetree.piczo.com. I-10 exit 333 N CR 125N 2.6 mi field on right. 3 motels within 5 mi RV ok elect available for charging, Fri nite dinner landing fee \$20 all three days or \$10 1 day includes 1 raffle tkt and 1 meal tkt, 80" mono 60" bi or true ¼ scale, 100% of proceeds go to American Cancer Society. Sponsor: SHADETREE

Chief Treasurer- Sam Varn

Editor's Note: The Treasurer's report is published for Members only. The public version of the Newsletter does not include account balances.

Petty Cash: **\$0.00** Premier Checking: **\$0.00**
Capital City Savings: **\$0.00**
Total Funds: **\$0.00**

Capital City Checking: **\$0.00**
SunTrust CD: **\$0.00**

Sam

Chief Scribe- Steve Warmath (Mike Atkinson took notes for me)

The September meeting was called to order at 7:07 pm Thursday September 4, 2008.
No visitors or new members were present

Sam Varn read treasurer's report. The membership voted to approve the report. At the conclusion of his report, Sam announced he would be stepping down as treasurer at the end of this term in December.

Old business:

- There was no additional information on establishing electrical power to the field. The general thought is the county will not be financially able to assist us at this time.
- The previously allotted generator money has not been used, as we are still looking at generators and their respective noise levels.
- The road leading to the field was graded, but tropical storm Faye damaged it again. There is a possibility of some left over gravel being available for use in repairing the road. We will continue to look into that option.

New Business

- Shannon noted the passing of fellow member, Brian Campbell. The club made a financial donation to Hospice, as requested by his family. Brian's wife has donated 3 cases of fuel to the club, which will initially be used for trainer plane usage.
- Upcoming club events: Fall Fly-in – October 11, 2008, Warbird Fly-in – December 6, 2008, Float Fly-in TBA in November.
- A decision was made regarding the memorial plaque for the field. The club has commissioned Sam to design a Corian plaque approximately 12" x 15" with space for 12-18 nameplates. Former club members who have passed will be listed on the plaque with the year of their death included. Anyone with information on previous members, please contact one of the officers.
- Shannon reminded us there are a few members still coming out and flying who have not paid their dues. Very soon, a no-fly list will be posted at the field.
- Fred Schmidt announced the Killearn Lakes picnic would be in November. John Hall provided demonstration flights last year. Fred will get us an exact date and we'll try to arrange a demonstration team for the event.

- Although we originally intended next month's meeting to return to Grace Lutheran Church, it was decided to conduct the October 2, 2008, meeting at the field and return to the church in November after the time change.
- The fun-fly series will resume Saturday, September 6, at 12:00 noon.

The meeting was adjourned about 7:30 p.m.

How to Align Cabane Struts on Biplanes and Parasol Aircraft

My Sig Smith Miniplane, like most biplanes, uses cabane struts to mount the wing. The core of the mount is a plywood plate in the fuselage (F10). The plywood mounts to 1/4" x 1/2" balsa stock that must be perfectly aligned on both fuselage sides. If these are wrong then everything that follows will also be wrong.

There are two brass tubes that are J-bolted and epoxied to the plywood plate. These must also be perfectly aligned.

Into these tubes are epoxied the four cabane pieces. Each of the cabane pieces is made from 1/8" music wire and is bent into a Z shape more or less. The arrangement makes a parallelogram that may or may not be straight, true and level by the time it is finished. A diagonal piece of music wire is wire wrapped and soldered to the cabanes. When this is complete two pieces of brass plate are wrapped around the top of the cabanes and soldered in place. Between the brass pieces is another piece of plywood that is epoxied in place.

Assuming the plate and tubes are correct in the fuselage, it is still possible to have one set of cabanes rotate further forward or aft of the other. This will result in the wing being lower on that side of the aircraft. In theory, the diagonal piece will ensure that the cabanes on both sides are identical. It does not work out that way in practice unless careful measurements are taken.

First I tried to block the fuselage level and perpendicular to the building surface. That meant dropping a centerline from the fuselage to the building surface as a reference line. From this line I would have to go back up to the cabanes to ensure they were aligned properly to the fuselage and each other.

I messed around with this for about an hour before coming to the conclusion that I just couldn't do it with any degree of accuracy. Eye-balling it would have given me close to the same result.

Then I had a brainstorm. I knew that the firewall was perpendicular to the fuselage centerline in both top and side view so it could be used as a reference. Here's how I did it: First I bolted the fuselage to a flat board using the blind nuts installed for the engine mount. I wasn't concerned that the fuselage aligned perfectly to the board. I just wanted to make sure that both sets of cabanes were over the board when the time came to set them up. With the fuselage bolted to the board the first set of cabanes is set up as closely as possible to what is indicated on the plan. The

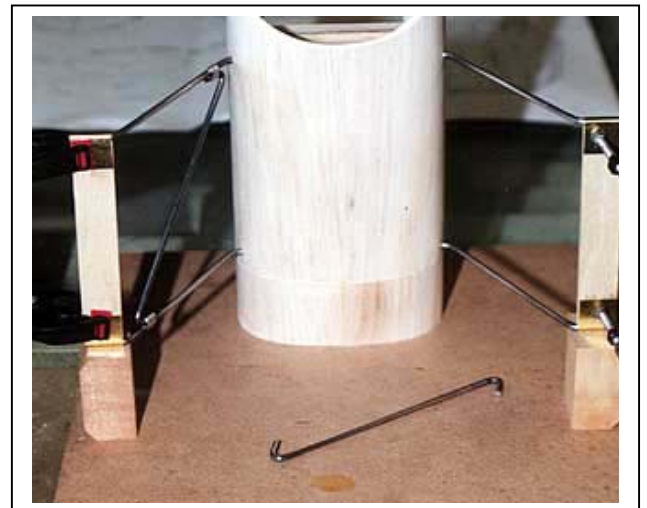
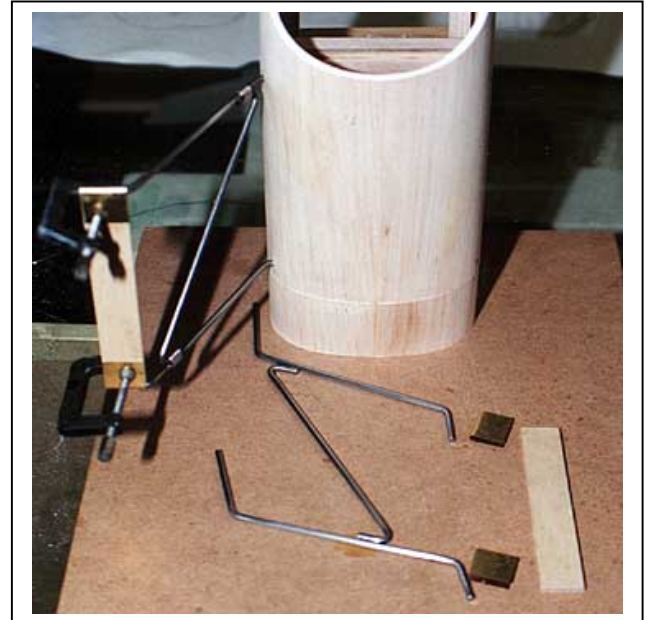
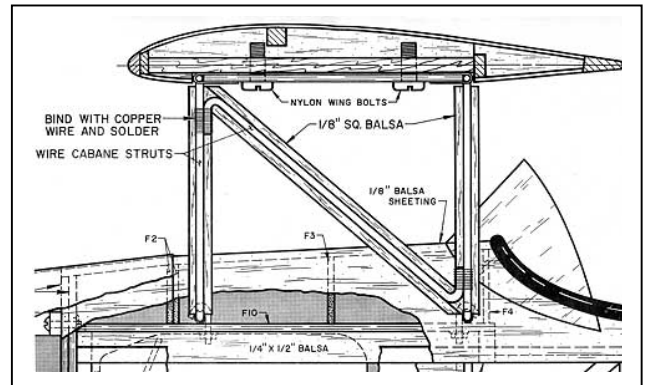

cabanes are supposed to be perpendicular to the thrust line (side view). The brass and plywood pieces are clamped in place temporarily to ensure the cabanes are properly spaced. When I was satisfied with the alignment I wrapped and soldered the diagonal strut to both the front and rear cabanes. I used rosin-core electronics solder.

Note that metal clamps are used. They act as heat sinks and do not melt.

A block is cut to be a perfect fit underneath the cabane that had been soldered. A cut-off from the same block is under the second cabane assembly.

In retrospect it is a better idea to make the blocks before soldering the first cabane.

I did not have enough metal clamps for both cabane assemblies, so I have switched the metal clamps to the assembly about to be soldered. The completed assembly has cooled and plastic clamps have replaced the metal ones.

Now both cabanes are soldered and align perfectly to one another.

Note my expensive, high-tech acid brush carefully fashioned from a scrap of imported South American balsa.

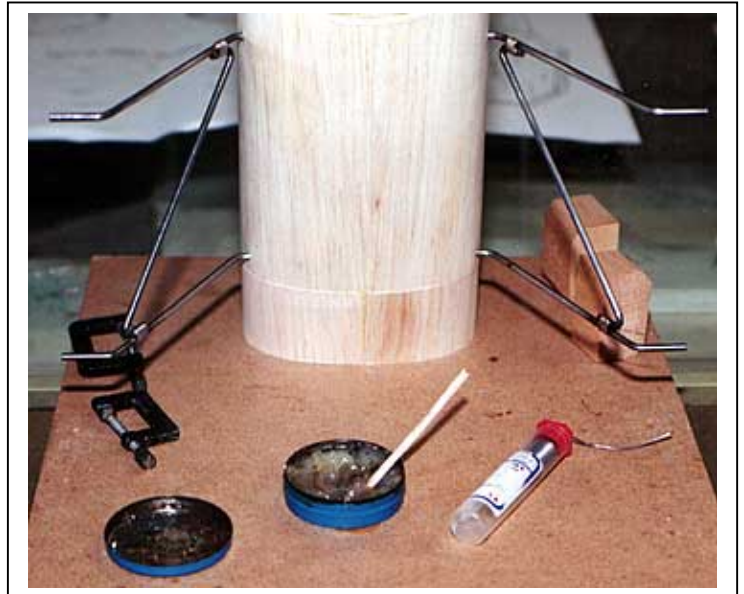

How are Your Nicads? by Ted Brindle

The Nicad batteries that we use in our transmitters and aircraft wear out with time. If you have a battery pack that is more than three years old, you should be keeping a close check on it by cycling every month. If it is five years or older, you should replace it and be sure to properly dispose of the old cells. So, how do we tell the age of our batteries?

Most Futaba battery packs and individual Sanyo battery cells (which most OEM radio manufacturers use) have a two-letter date code stamped somewhere on the pack or cell. The first letter of the code is the year of manufacture and the second letter is the month of manufacture. 1996=A, 1997=B, 1998=C, etc.

January=A, February=B, March=C, etc.

If you have a battery or pack with a date code of IB, it was manufactured in February of 2004. Probably still okay but keep a close check on it. The pack in my 8UAF transmitter was ZF, or June of 1995 so I replaced it. I found one pack with a date code of WC, which translates to 1992; replaced that one without question.

[From the Suffolk Aero Modelers, Long Island, New York](#)



Seminole Radio Control Club Tallahassee, FL

AMA Charter #216, 1969-2008

SRCC Officers

President – **Shannon Black**
Vice President – **Mike Atkinson**
Secretary/ Newsletter Editor – **Stephen Warmath**
Treasurer - **Sam Varn**
Field Marshall – **Joe Satterwhite**
Field Safety Officer- **Gordie Meade**

Field Hours

12 Noon till Dark- These hours apply to **all** aircraft, gas **and** electric.

Training Notes

To schedule a training time contact Mike Atkinson.

Flight Instructors

Mike Atkinson- Primary/ Advanced Flight Instructor (Coordinator)	926-4692
Geoff Lawrence- Primary/ Advanced Flight Instructor	942-9807
John Hall- Primary/ Advanced Helicopter Flight Instructor	893-6457
Jay Leudecke- Primary/ Advanced Helicopter Flight Instructor	508-7135
Jeff Owens- Ground School/ Airworthiness Instructor (Fixed Wing)	894-2504
Frank Bastos- Hobby Town Flight Demonstrator	671-2030

Club Meeting Location and Time

November- March: The regular club meetings are held on the first Thursday of each month at **7:30 PM** at the Grace Lutheran Church on Miccosukee Rd. Head out Miccosukee Rd., cross Capital Circle NE, and the entrance will be the first one on your right. Once you park, follow the sidewalk around the left side of the building and go down the hill. We meet in a room on the first level.

April- October: The regular club meetings are held on the first Thursday of each month at **7:00 PM** at the Flying Field. The Club offers food and drinks for a small charge.

Newsletter Submissions- Submissions are requested to be in M.S. Word format or via e-mail text. Photos should be in .jpg or .tif format. Vector art accepted in Corel, Illustrator and AUTOCAD format. We will, however, accept anything to make it easier for those who wish to contribute. Submissions are due no later than the 23rd of the month. Send your submissions to ssw@nettally.com or by phone, Steve Warmath at 509-0672.

Hard Copy Printing of the SRCC
Newsletter provided by Apogee
Signs & Graphics. 850-224-7446



ap-o-gee (n) - The farthest or highest point; the apex.

apogee SIGNS & GRAPICS is a division of 1 Hour Signs, Inc. ES12000314